

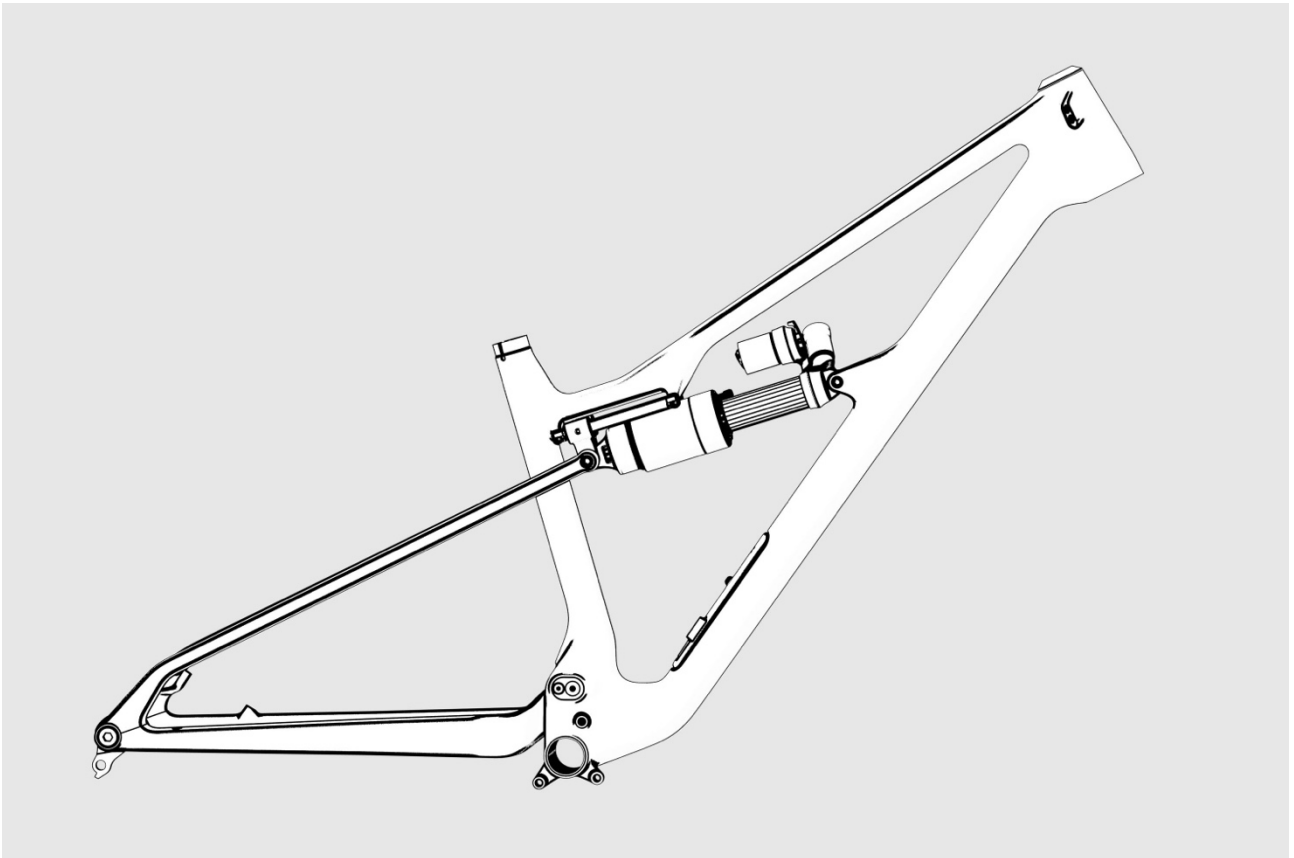

Manual

EXTRA AIR & EXTRA COIL ASSEMBLY INSTRUCTIONS

Congratulations on purchasing your Extra frameset. In the following instructions, we will guide you step by step through the assembly of your new bike. Proper assembly is essential to unleash the full potential of this product and, more importantly, to ensure a safe ride. Otherwise, serious injuries or even death may occur. Therefore, we strongly recommend having your bike assembled by a qualified bicycle mechanic. The assembly of your bike should follow the steps described in this document.



Extra Air frameset

Before you begin

Make sure you have all the necessary tools and expertise to perform the described steps. All screws must be tightened using a calibrated torque wrench. When installing third-party components, ensure they match the compatibility list provided at the end of these instructions, and follow the manufacturer's guidelines.

Assembly Seat Post

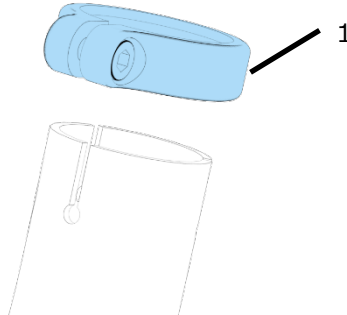

Pos.	Description	Torque
1	ARC8 seat clamp 34.9	6 Nm

If you're working on a mounting stand with a holding claw, installing the seat post should be your first step. Clamping the frame itself in the mounting stand can damage it! For tasks requiring significant force (e.g., bottom bracket installation), the frame must either be supported by wheels on the ground or using a mounting stand with bottom bracket/axle fixation.

1. Apply carbon assembly paste to the seat post and the inside of the seat tube. Do not use grease.
2. Tighten the seat clamp to a maximum of 6 Nm.

Cable Housing & Brake Line Installation

We recommend routing the cables from rear to front, towards the head tube. Begin with the cable housing for the seat post. Remove the cover from the stop box. Insert the cable housing from the top into the seat tube, then push the housing into the upper, laminated guide on the right side of the frame.

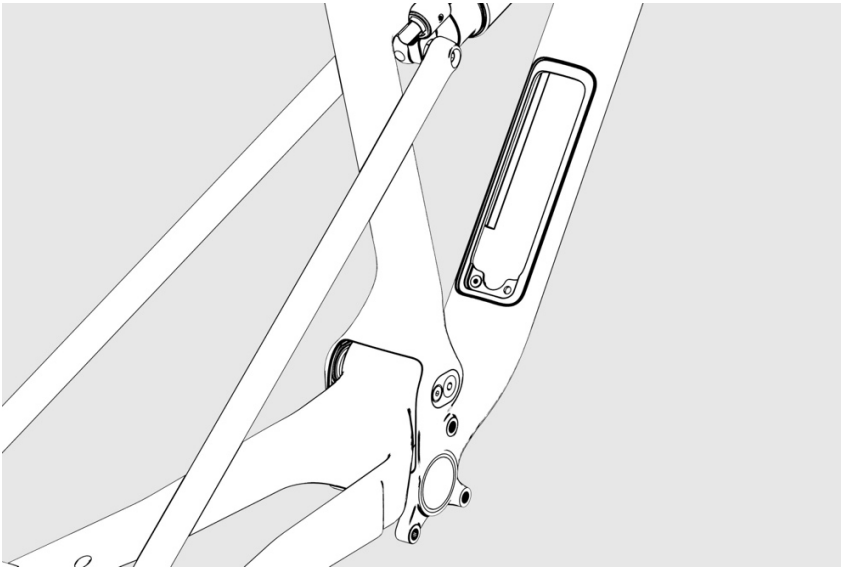

Now, pull the cable housing slightly out of the corresponding frame opening at the head tube and leave it there.

Next, install the shift cable housing. To do this, feed the housing through the opening in the right chainstay. The housing will then appear at the bottom bracket area in the main frame. Now, push the housing into the upper laminated guide on the left side of the frame. Then, pull the cable housing sufficiently out of the corresponding frame opening at the head tube so that it can later be connected to the shift lever.

For routing the rear brake line, insert the line into the opening in the left chainstay. The line will also appear at the bottom bracket area in the main frame. Now, push the line into the lower laminated guide on the left side of the frame. Then, pull the brake line sufficiently out of the corresponding frame opening at the head tube so that it can later be connected to the brake lever.

Prefer to run your brake "Moto-Style"? Then, instead of inserting the line into the left lower guide, simply insert it into the lower guide on the right side of the frame.

Slider and Shock Assembly

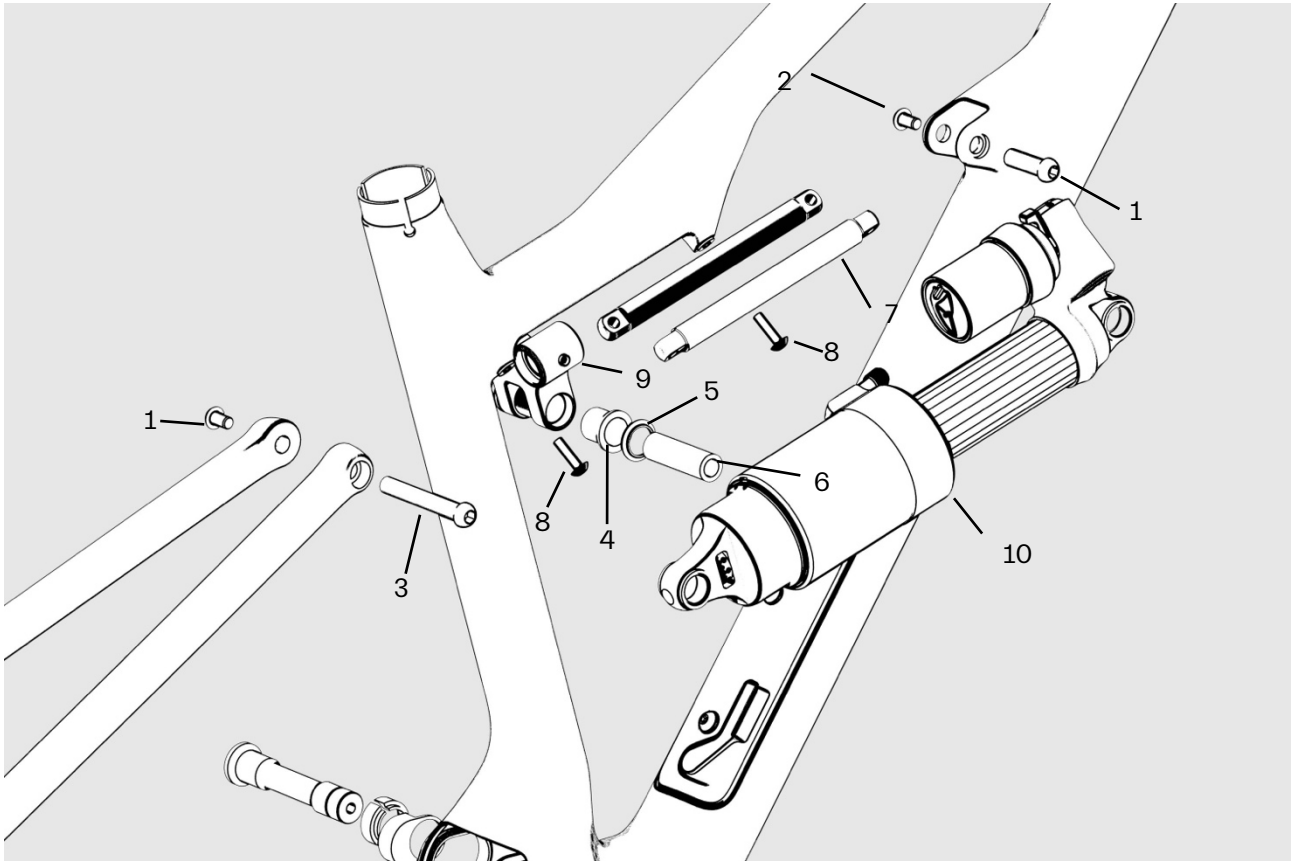

Pos.	Description	Quantity	Torque	Note
1	Button Head Bolt M6	12	6 Nm	Use thread locker
2	Extra Shock Axle Front	1	6 Nm	
3	Extra Shock Axle Rear	1	6 Nm	
4	Extra Shock Bushing	2		
5	Extra Slider Spacer	2		
6	Extra Shock Pin	1		
7	Extra Slider Rail	2		
8	Button Head Bolt M5	16	5 Nm	Use thread locker
9	Extra Slider Housing Unit	1		
10	Shock	1		

ARC8

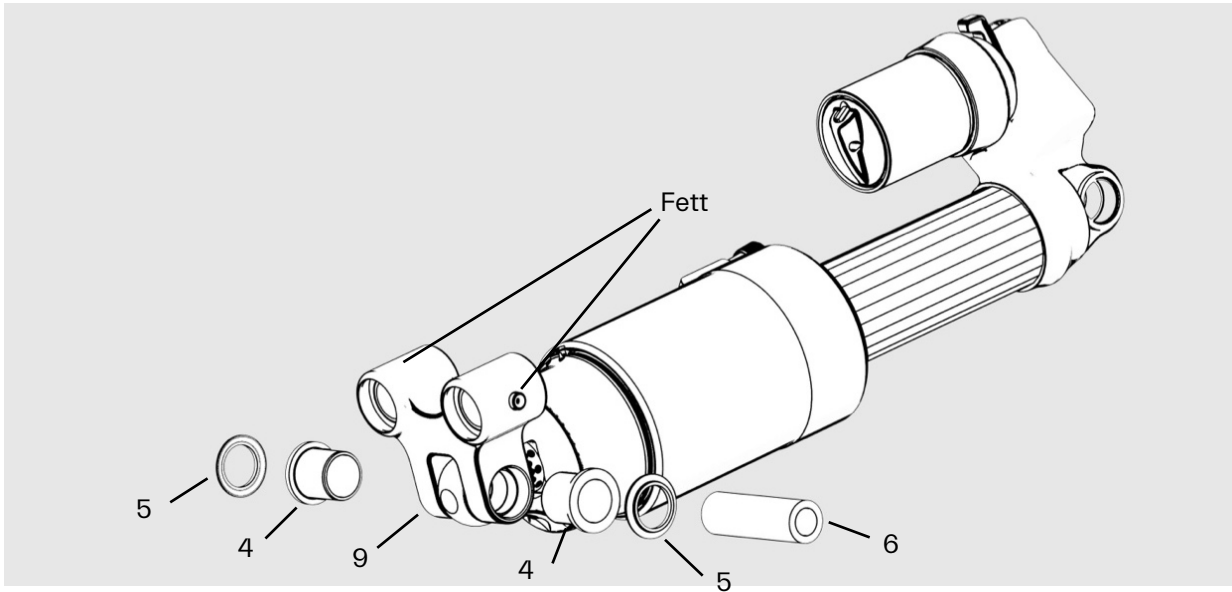

ARC8

Grease the two plain bearings in the carriage (9). Place the shock absorber in the carriage and press in the two shock absorber bushings (4). Insert the shock pin (6) through the shock absorber bushings and place the two spacers (5) on it, ensuring correct spacer orientation.

Position the shock absorber in the frame and secure it with the shock absorber axle (2), which you do not need to tighten yet. Slide the two guide rods (7) through the carriage and attach them with the two screws near the seat tube. Tighten them only lightly. Now, remove the shock absorber axle (2) and slide the carriage forward. Tighten the two screws (8) at the front to 5 Nm. Then, slide the carriage back and tighten the two rear screws to 5 Nm. Check that the carriage moves with little effort and place it approximately in the middle of the guide rods. Ensure that the two spacers (5) are in the correct position, and move the rear assembly so that you can push the rear shock absorber axle (3) through. Tighten this with 6 Nm. Now, slide the carriage back and tighten the front shock absorber axle (2) with 6 Nm.

If there are signs of wear on the guide rods, replace them together with the carriage.

Main Pivot

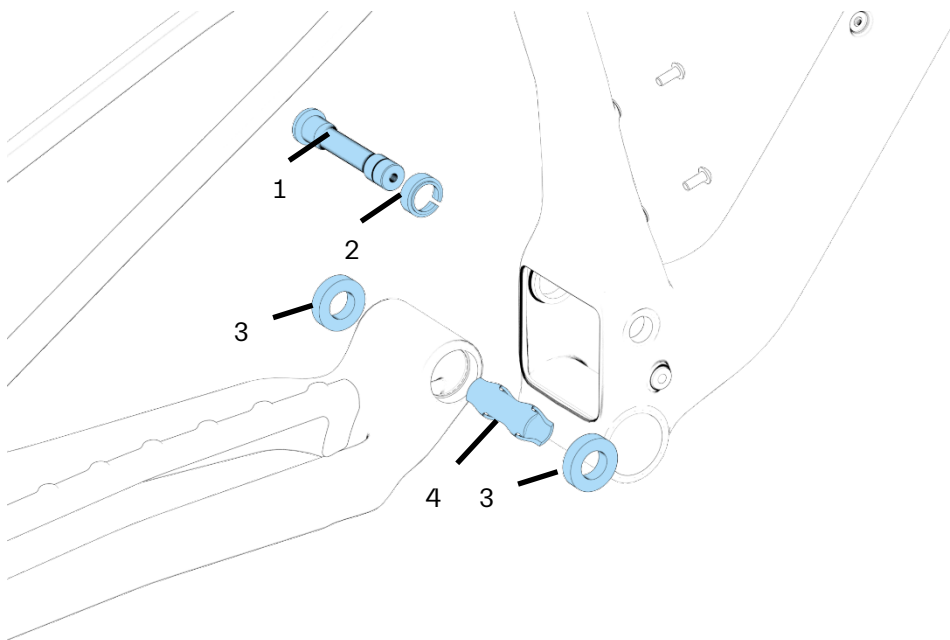

Pos.	Description	Quantity	Torque
1	Main Pivot Axle	1	15 Nm
2	Split Ring	1	
3	Bearing 6902	2	
4	Bearing Spacer	1	



Dismantling

Before working on the main pivot point, remove the front shock absorber axle and slide the carriage approximately to the middle of the guide rods.

To dismantle the main pivot point, remove the axle (1) and the split ring (2) using an 8 mm Allen key. Now, you can pull the rear assembly out of the main frame.

The spacer (4) has cutouts, allowing you to knock the bearings out using a drift punch. Do this evenly to prevent the bearings from getting jammed and damaging the bearing seat.

Montage

Before installing new bearings, grease the bearing seats in the frame and ensure that the spacer is between the bearings.

For assembly, grease the thread of the axle (1) and the contact surfaces between the axle and the split ring (2). Place the split ring on the axle. Ensure that the spacer (4) is aligned between the bearings, position the rear assembly in the main frame, and slide the axle through the bearings. Tighten them to 15 Nm.

FlipChip Introduction

The FlipChip allows you to switch between a 29" and a 27.5" rear wheel without changing the geometry, with the exception of the chainstay length. You can use a 27.5 inch rear wheel in the 29 inch setting or vice versa, but please note the following points:

1. We strongly recommend that you use as short cranks as possible should you use the 27.5 inch rear wheel in the flip chip position for 29 inch.
2. If you use a 29 inch rear wheel in the flip chip position for 27.5 inches, make sure that the rear wheel does not collide with the seat tube at the stop. This depends on the tire choice.

FlipChip Adjustment

1. First remove the rear wheel.
2. Although it is possible to do a FlipChip adjustment without this step, we recommend that you loosen the bolt that attaches the seat stays to the slider and shock.

ARC8

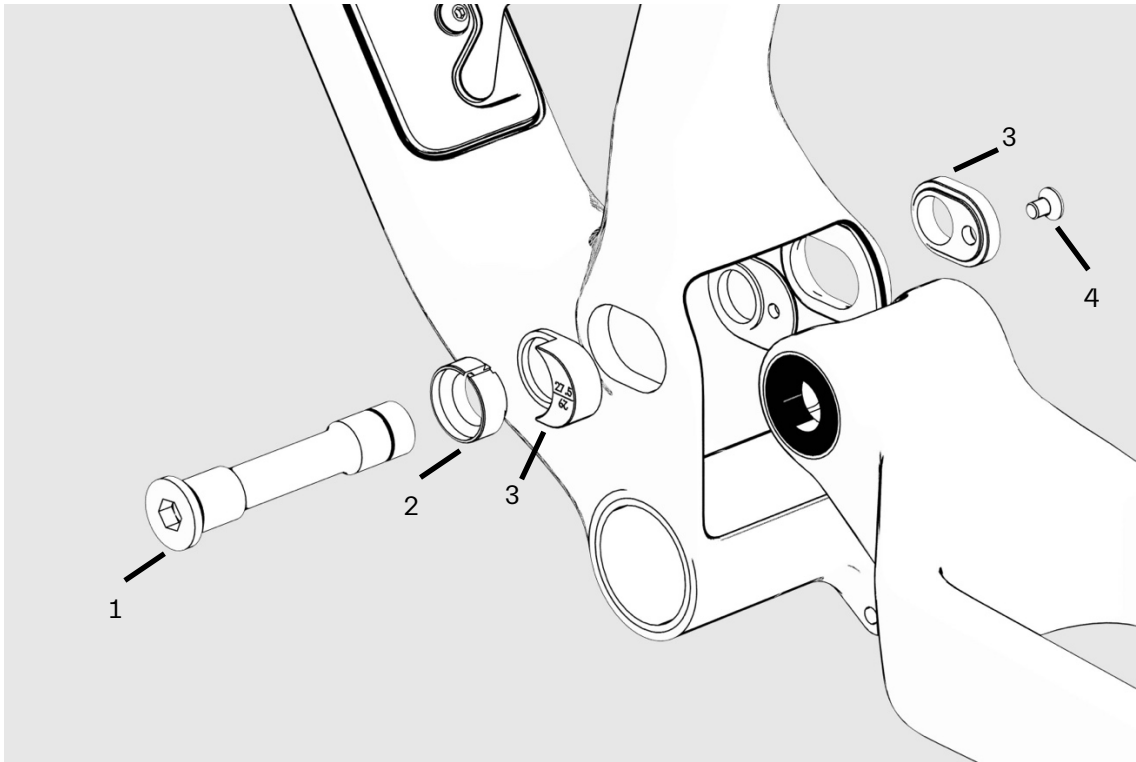

Pos.	Description	Quantity	Torque
1	Main Pivot Axle	1	15 Nm
2	Split Ring	1	
3	FlipChip		
4	Screw	1	

3. Remove the main axis of rotation (1).
4. Pull back the swing arm.
5. Remove the clamp and the FlipChip (3) on the non-drive side.

ARC8

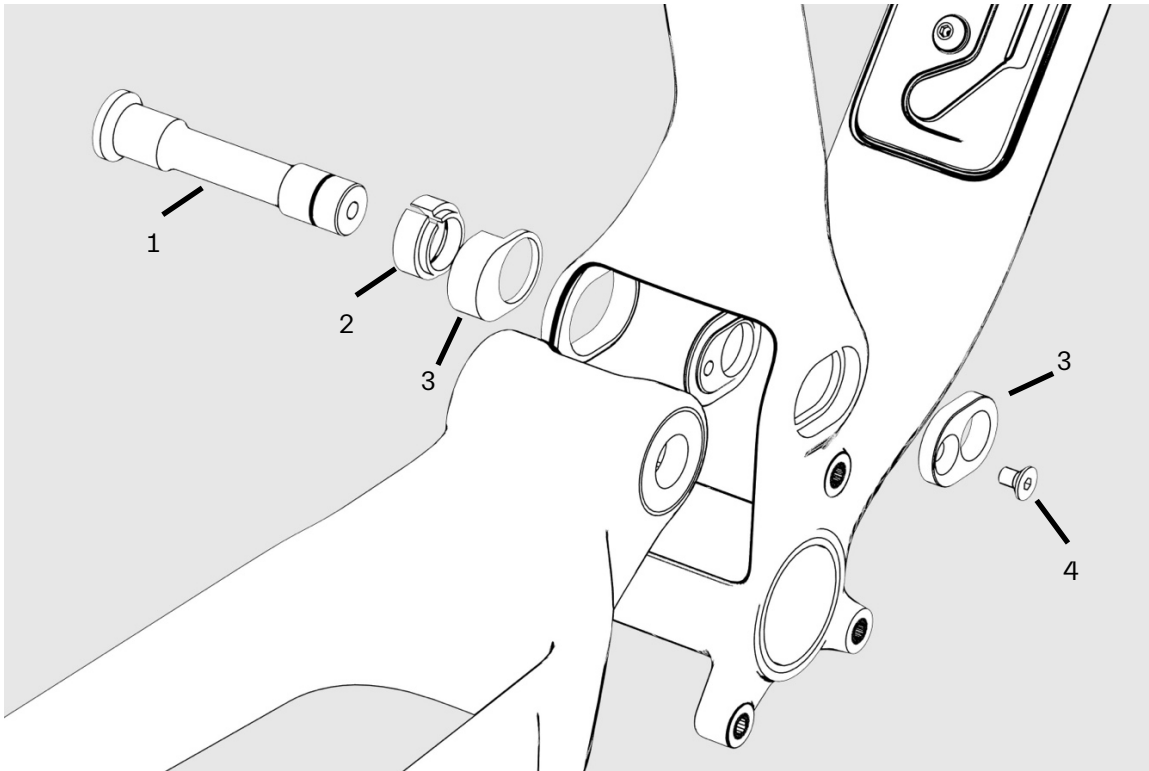

6. Use a 3 mm Allen key to loosen the countersunk screw (4) in the FlipChip on the drive side.
7. Remove the FlipChip on the drive side (inside and outside) and turn it over.
8. Apply Loctite 222 to the thread of the countersunk screw (4) and tighten it to 2 Nm.

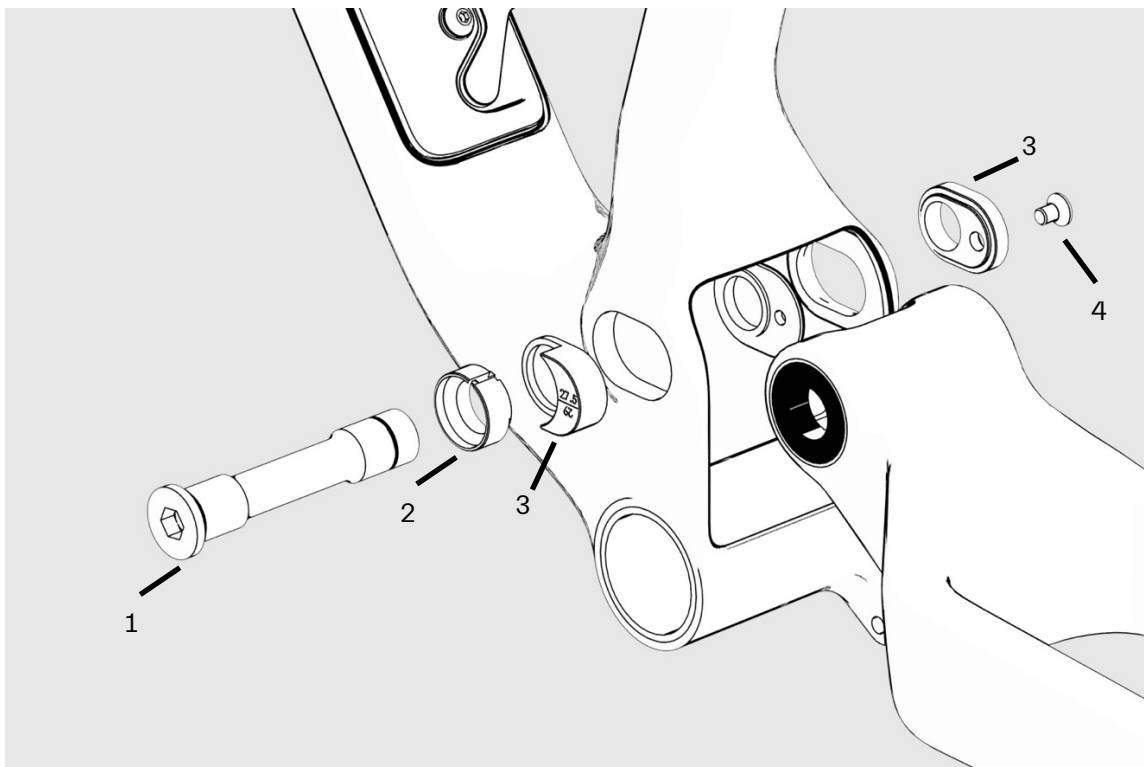

9. Install the flip chip and clamp (3) on the non-drive side.
10. Make sure that the spacer (2) is still positioned between the bearings and place the swing arm inside the main pivot area of the front triangle.
11. Install all the main pivot axle (1) and tighten it to 15 Nm..

RD Hanger & Thru Axle

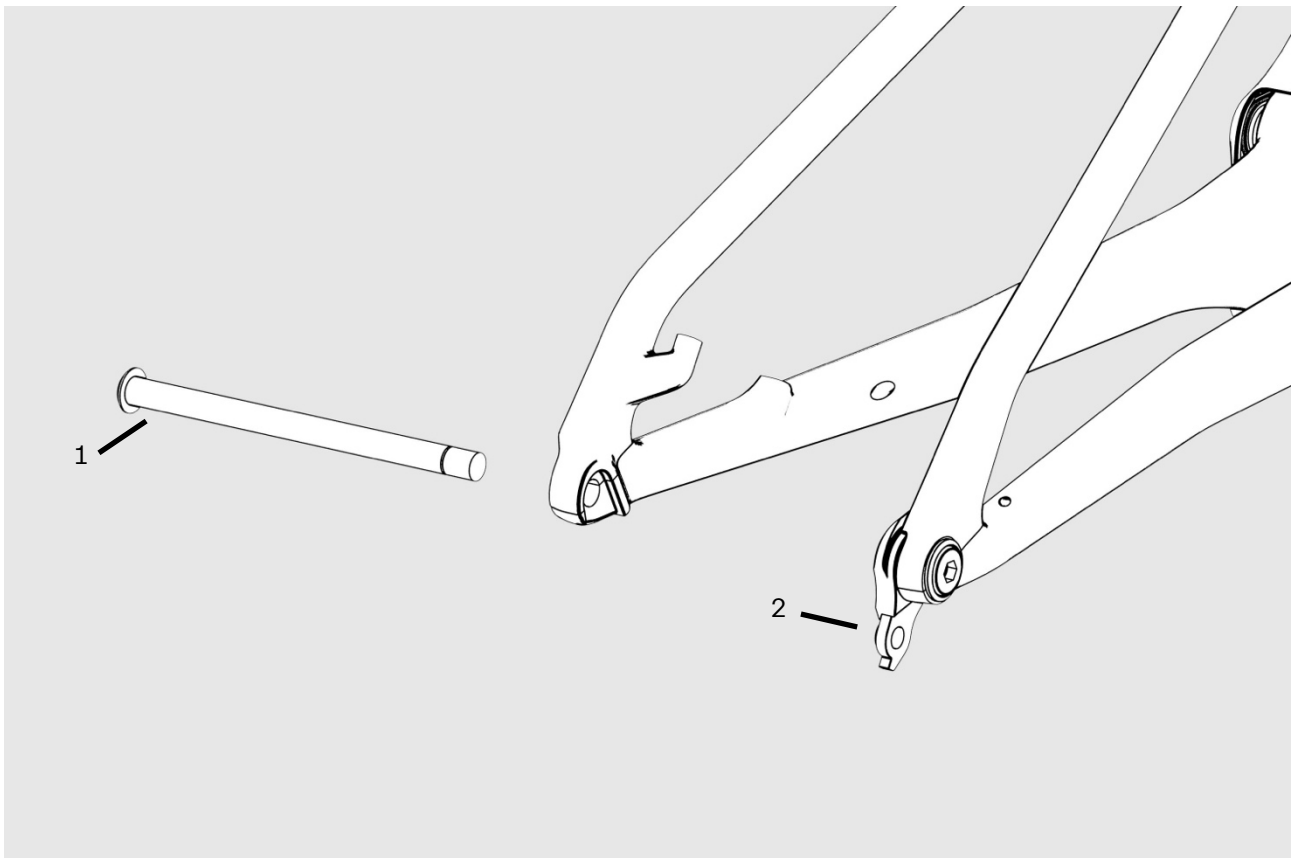

Pos.	Description	Torque
1	UDH Thru Axle	10 Nm
2	SRAM UDH	10 Nm

Follow Sram's instructions for installation.

Bottle Cage

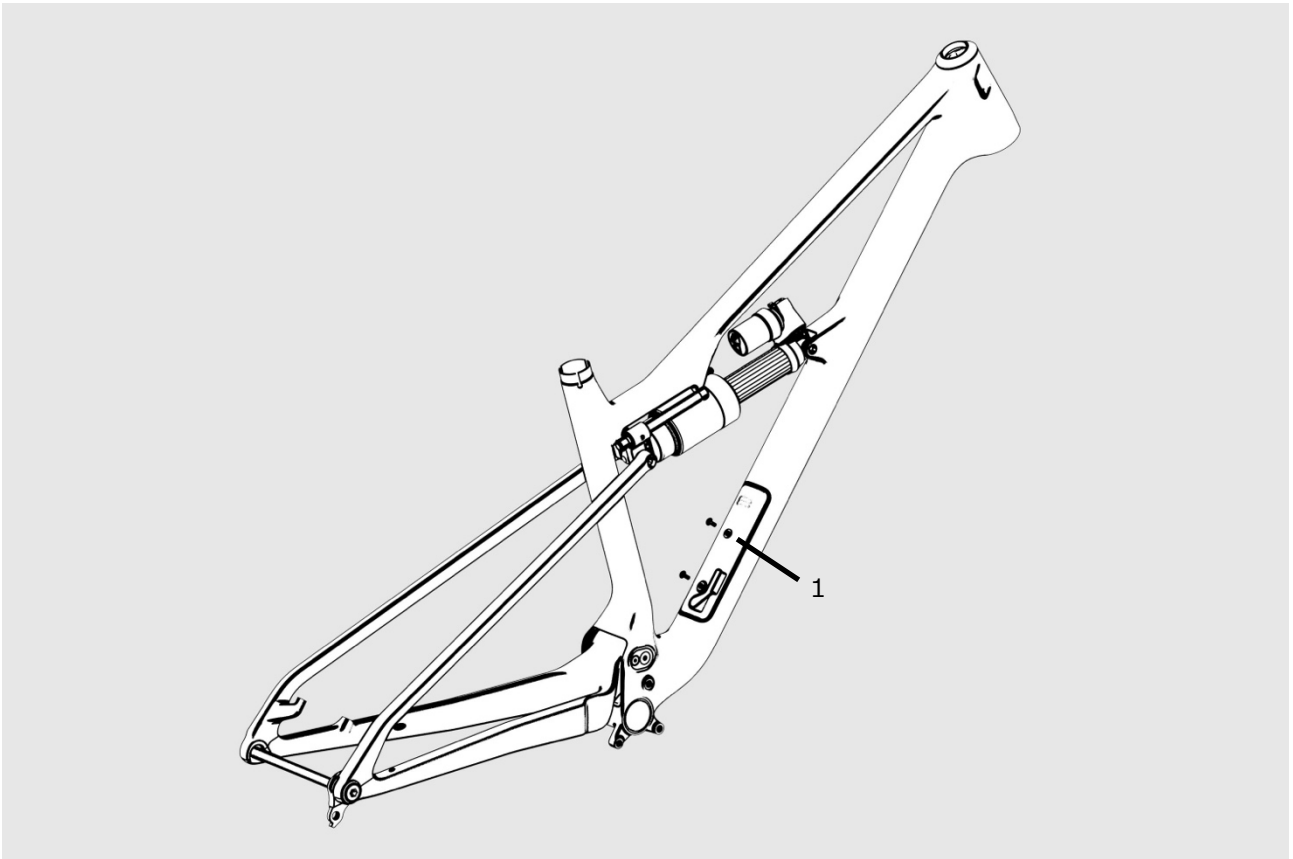

Pos.	Description	Torque
1	Bottle Cage Bolt	5 Nm

You can mount a bottle cage on the lid of the Stopfbox (1).

Stopfbox

You can store your emergency tools in the stuffing box. The small pocket under the lid is suitable for a mini tool. We recommend the Topeak Nano11, for example. In the other two pockets you will find space for a small pump or CO2 cartridge, as well as a thin tube with tire levers. Here we recommend Aerothan tubes from Schwalbe, for example, as these can be folded up to save a lot of space.

Frame cover

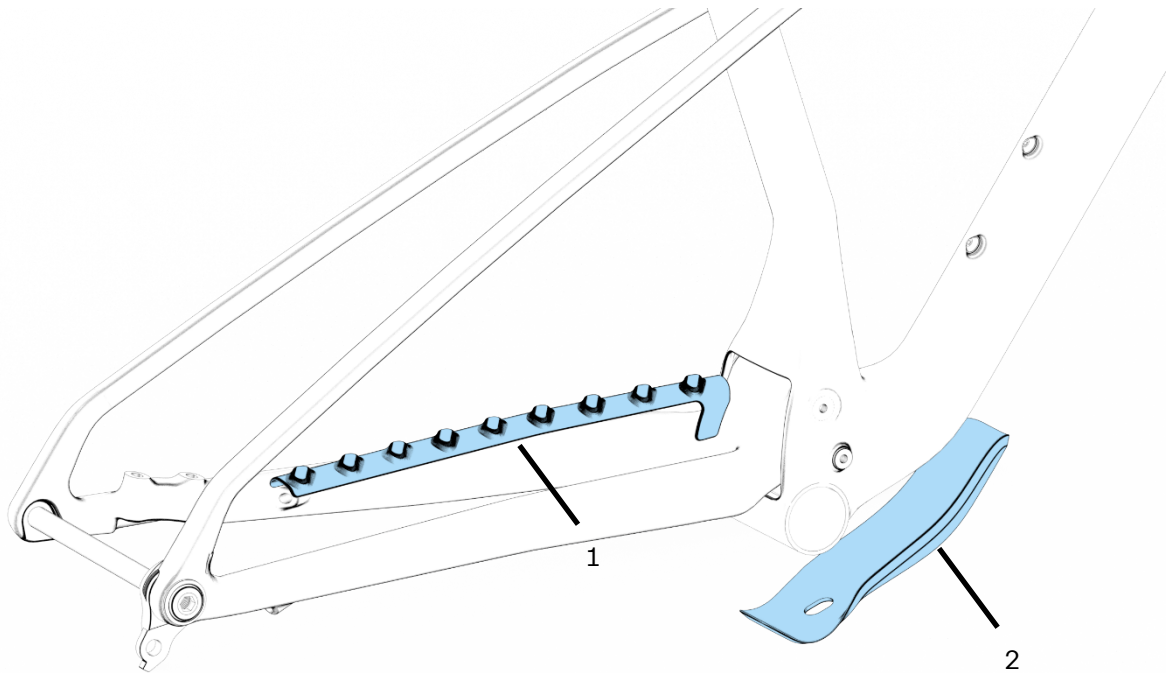

Pos.	Description
1	Extra Chainstay Protection
2	Extra Downtube Protection (Abb. ähnlich)

The Extra has a ribbed chainstay protector and a frame guard on the down tube. They are attached using 3M double sided adhesive. Clean the surfaces of the frame with alcohol before assembly.

Maintenance

After every ride: Make sure that all bolts are tightened to the specified torque. Clean the bike and visually inspect it for damage. Make sure that the headset has no play.

Every 1000 km: Remove the fork and inspect for any visible damage on the steerer tube and crown area. Externally clean and re-grease headset bearings.



Parts Compatibility Table

Part	Specification	Comment
Brake	Postmount 203 mm	203 mm without adapter. Mount height 25 mm
Tires	29 x 2.4" max	Because tire width varies with rim width and manufacturers, make sure there is at least 6 mm of clearance all around the tire.
Seat post	Ø31.6	
Seat clamp	Ø34.9	
Headset	Acros	320.52.514R3F-OD46 Acros AiX-322 R3, flach OD46 IS41,8/28,6, IS52/40
BB	BSA 73	
Chainrings	38 T max; 30 T min.	55 mm chainline
Chainguide	mounted	Also compatibel with: 77designz Freesolo V2-05+BSA
Fork	160 -180 mm travel, 1.5-1 1/8" tapered	Make sure, that the adjustment buttons don't touch the down tube.
Shock	250 mm length, 70 oder 75 mm stroke (160 oder 165 mm travel).	20 x 8 mm hardware on shaft side, no hardware on body to mount it on the frame.

Weight limit

This frame is designed and tested for a maximum total weight (rider plus bike plus equipment) of 120 kg.