



Manual

# ESCAPEE ASSEMBLY INSTRUCTIONS

Congratulations on purchasing an Eero frame set. In the following instructions, we will guide you step by step through the assembly of your new bike. Proper assembly is essential to fully realize the potential of this product and, more importantly, to ensure a safe ride. Otherwise, serious injury or even death may occur. Therefore, we strongly recommend having your bike assembled by a qualified bicycle mechanic.

The assembly of your bike should follow the steps described in this document.



Escapee Frameset

# ARC8

## Parts Overview

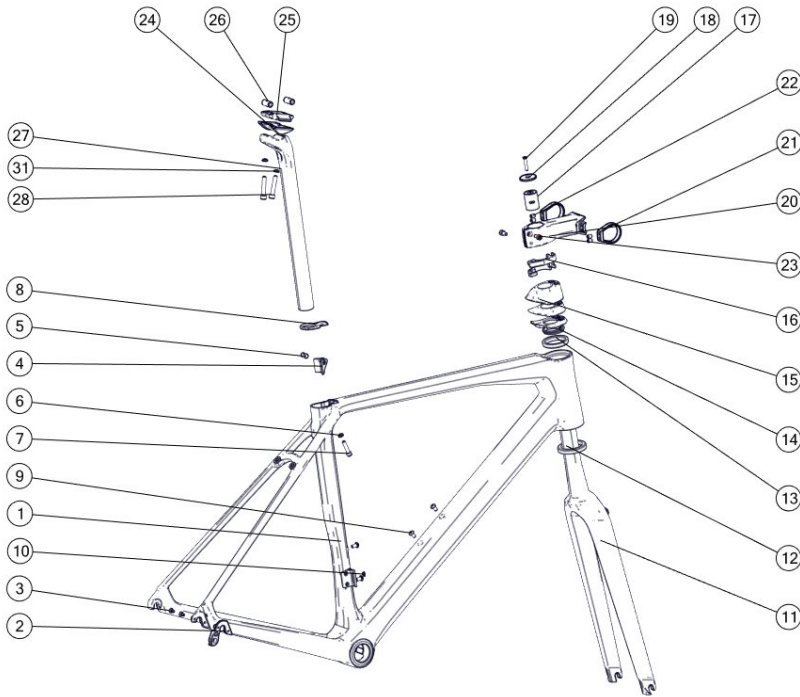

Description	BOM ID	Qty
Escapee Frame	1	1
Escapee RD Hanger	2	1
Escapee RD Hanger Bolt	3	2
Integrated Seat Clamp	4	1
Integrated Seat Clamp Nut	5	1
M6 Spherical Washer	6	1
Internal Seatclamp Bolt	7	1
Seat Tube Cover	8	1
Bottle Cage Bolt	9	4
DI2 Plug	10	1
Escapee Fork	11	1
ICH Lower Bearing	12	1
ICH Upper Bearing	13	1
ICH Road Compression Ring	14	1
Escapee Top Cone	15	3
ICH Spacer	16	2
Expander	17	1
Top Cap	18	1
socket countersunk head screw_iso	19	1
ICH Stem Body	20	1
ICH Handlebar Clamp	21	2
ICH Handlebar Clamp Bolt	22	4
ICH Steerer Clamp Bolt	23	2
Escapee Seatpost Lower Cradle	24	1
Escapee Seatpost Upper Cradle	25	1
Escapee Seatpost Barrel Nut	26	2
Escapee Seatpost Tube	27	1
Escapee Seatpost Bolt	28	2
M6 Spherical Spacer	31	2

### Escapee rim brake

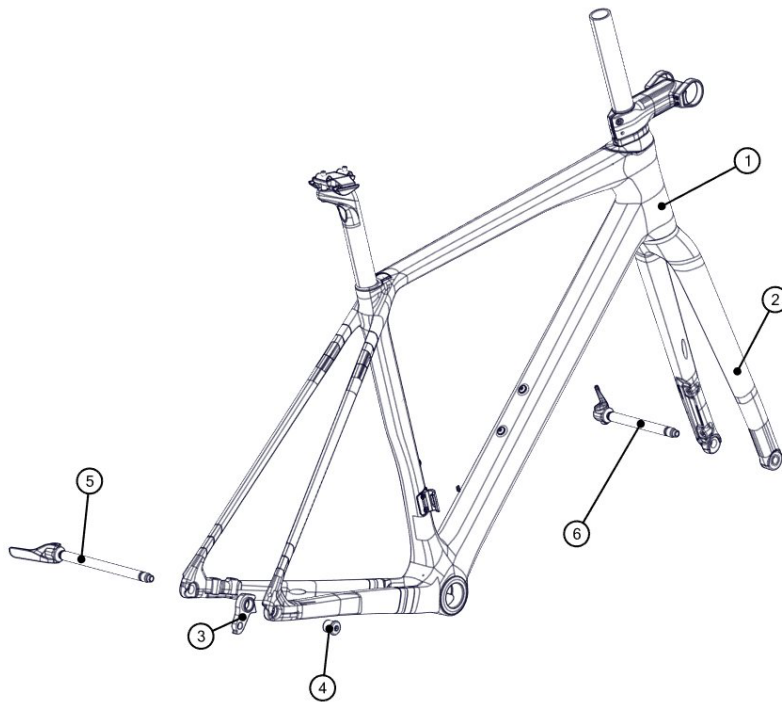

Description	BOM ID
Escapee db Frame	1
Escapee db Fork	2
RD Hanger E-Thru	3
RD Hanger Nut E-Thru	4
ARC8 TA 142	5
ARC TA100	6

### Escapee disc brake

Unnumbered parts are the same as for rim brake.

## Before starting

Make sure you have all the required tools and knowledge to do the tasks described here.

All bolts should be tightened using a calibrated torque wrench. For installation of third-party components, make sure they are according to the compatibilities listed at the end of this manual, and follow the instructions supplied by the component maker.

## Seatpost installation

If you are working with a clamp-type workstand, installing the seat post should be your first step. Clamping any tube other than the seat post might damage the frame. For tasks that require big torques, like tightening the BB, the frame needs to stand either on the ground (with wheels installed), or a BB/axle mount type workstand.

1. Slide the seat tube cover over the seat post
2. Apply friction paste on seat post and on inside of seat tube
3. Push the integrated seat clamp forward and slide the seat post into the seat tube. Make sure it is inserted at least to the minimum insertion mark. If you feel some resistance, do not force it further down. On smaller frame sizes, you might reach the area where the seat tube has the rear wheel cut-out and need a shorter seat post.

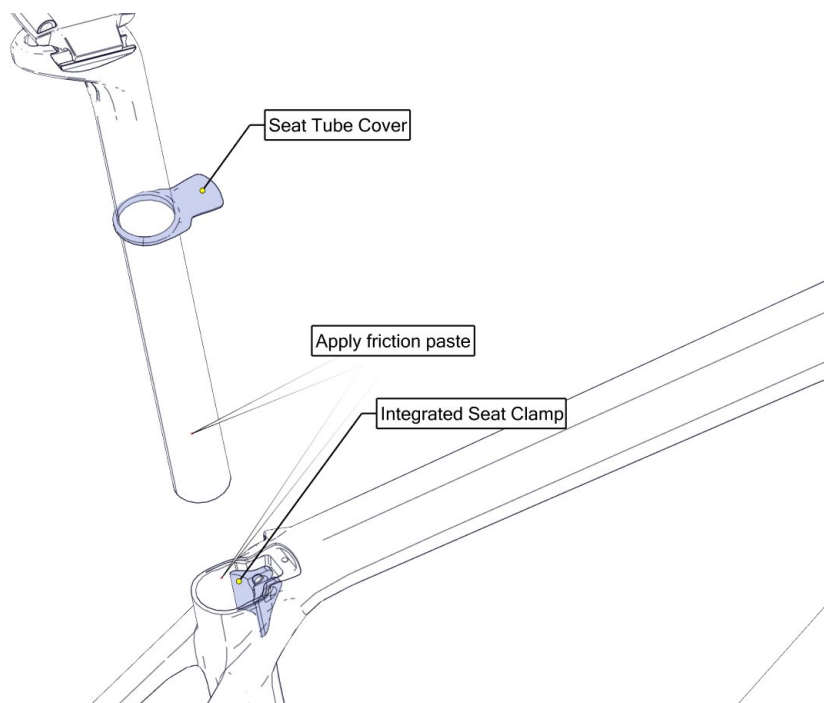

1. Tighten the seat clamp bolt to 5 Nm
2. Push the seat tube cover down

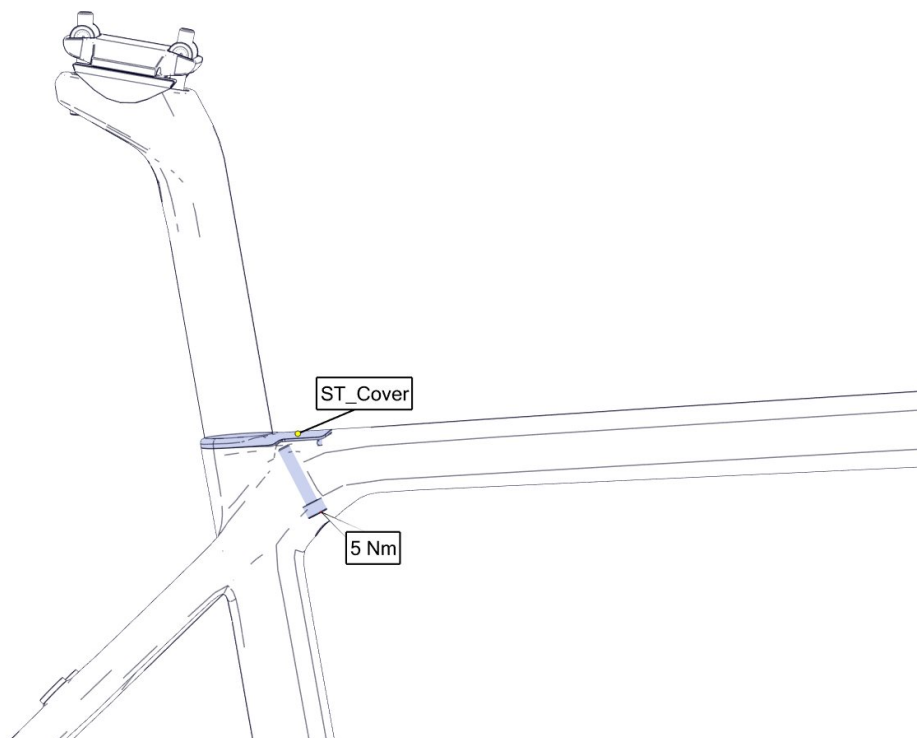

## Cable routing & fork installation

Note: For smooth function, it is important to use high quality, flexible cable housing.

1. Determine the correct steerer tube length for your fit by assembling the fork, headset bearings, compression ring, top cone, spacers (if needed) and stem. If you want to keep some spare steerer tube length for fit adjustment, you can place additional spacers above the stem. Mark the height of the assembly on the steerer tube, using a pencil or marker. Check twice before you cut!
2. Take some prevention not to inhale the carbon dust when cutting the fork. Wear a mask and use a vacuum cleaner to remove the dust during cutting. Cut the steerer tube using a carbon specific hacksaw blade (e.g. Park Tool CSB-1) and a cutting guide. You should cut it 2-3 mm below the mark you did in the step before. Make sure you do not damage the carbon by delamination. Smoothen the edges of the steerer tube using sand paper.
3. Apply friction paste to the inside of the steerer tube and insert the expander. Tighten the expander to 5 Nm.

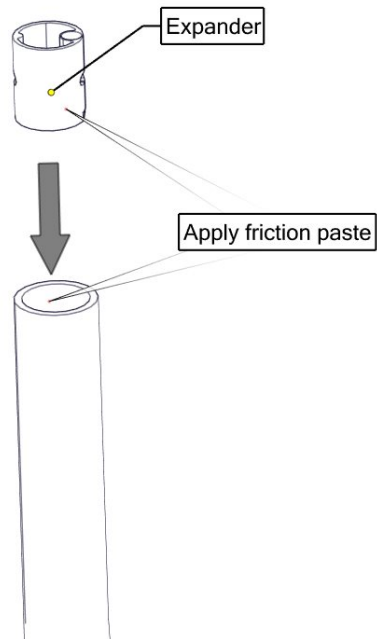

- Slide the cable housings through the frame. Work from the rear towards the head tube. Let the cables exit through the top of the head tube. Make sure the RD (and rear disc brake) cable passes above the BB shell, and use an end cap on the FD cable. Leave some extra length to the cable housing on either end.

For Di2, cables follow the same path as with mechanical shifting. They get connected above the BB by a junction box. Pull out the cables (from RD, FD, battery and handlebar) through the large openings inside the BB shell, connect them with the junction, and push the junction back into the frame. The battery gets stored inside the seatpost by an adaptor (e.g. Pro PRAC0094). Recommended cable lengths are indicated in the picture below.

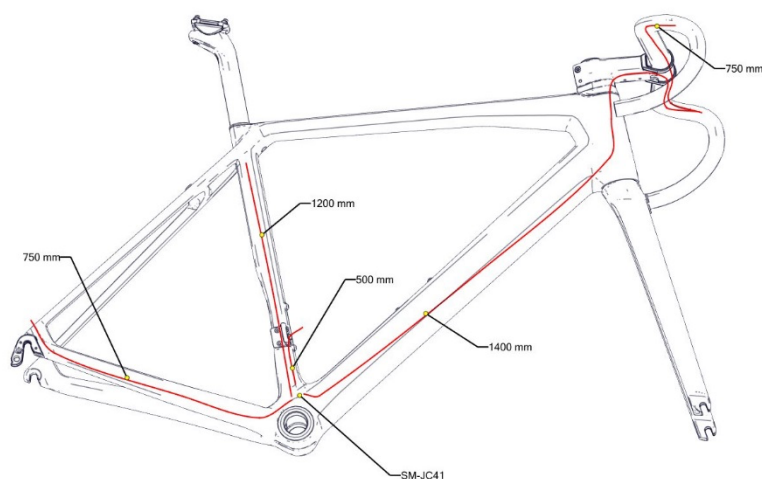

- To avoid rattling, slide foam tubes over the cable housing.

# ARC8

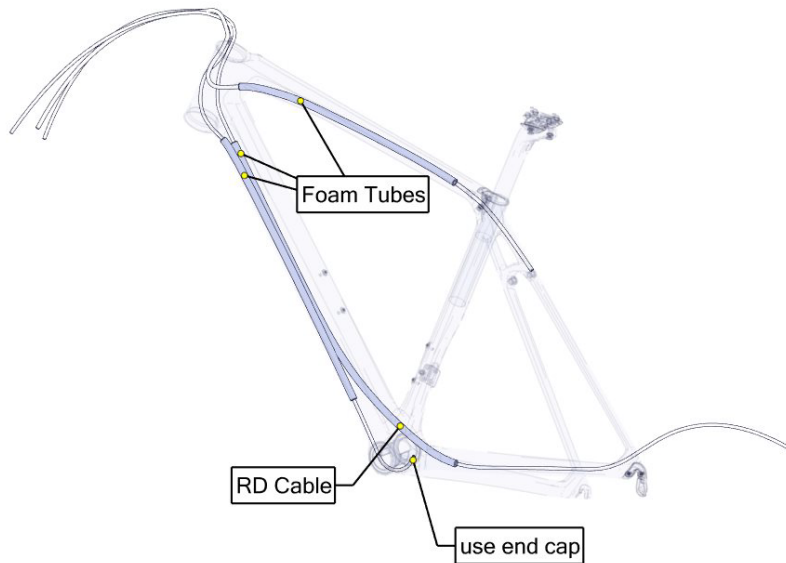

6. Apply grease to upper headset bearing seat and insert bearing.

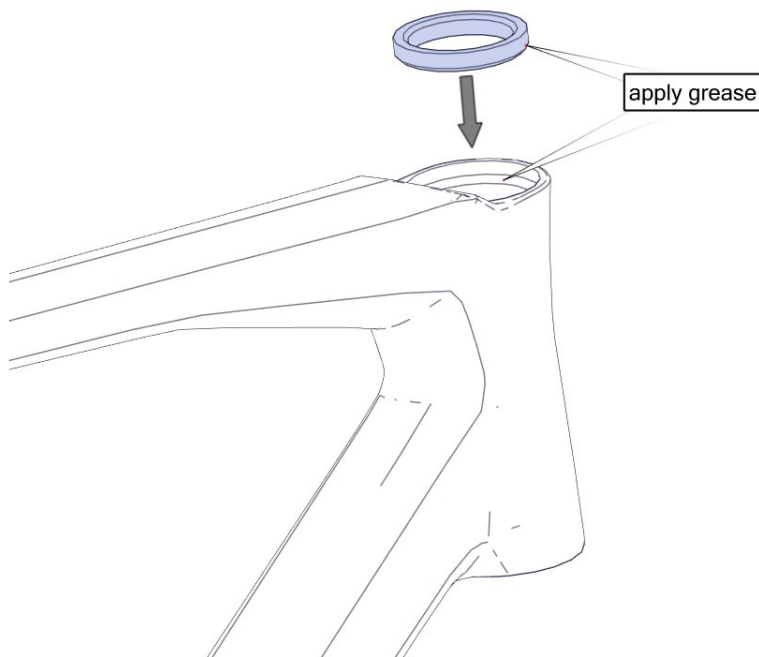

7. Install the front brake and feed the brake hose through the fork. Pull it out through the long hole in the fork steerer. Apply grease to the lower bearing, the integrated for crown race, and the lower bearing seat in the head tube. Put the lower headset bearing onto the fork, then insert the fork into the head tube. Make sure the rear derailleur cable and rear brake hose passes the steerer tube on the drive side, the other FD cable on the non-drive side.
8. Slide the compression ring over the cable housings. Make sure to use the holes as indicated. For Di2, use the slotted hole.

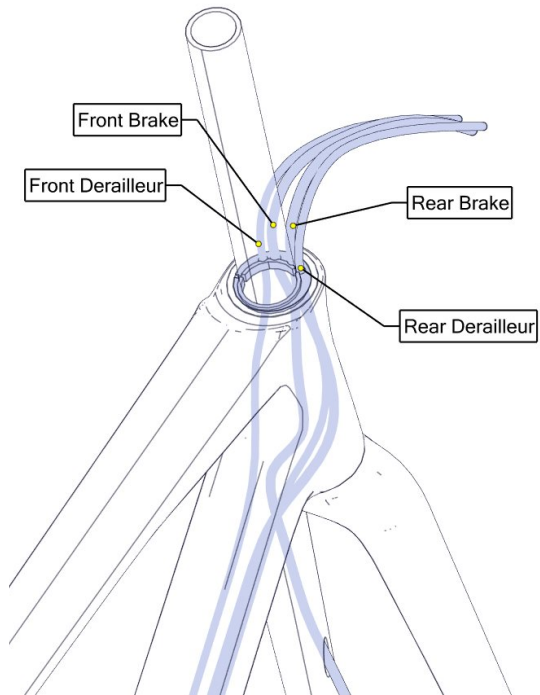

9. Slide the top cone and the stem over the cables. Make sure to select the suitable top cone for your fit. While spacers can be added and removed later, exchanging the top cone or the stem will need some more work.

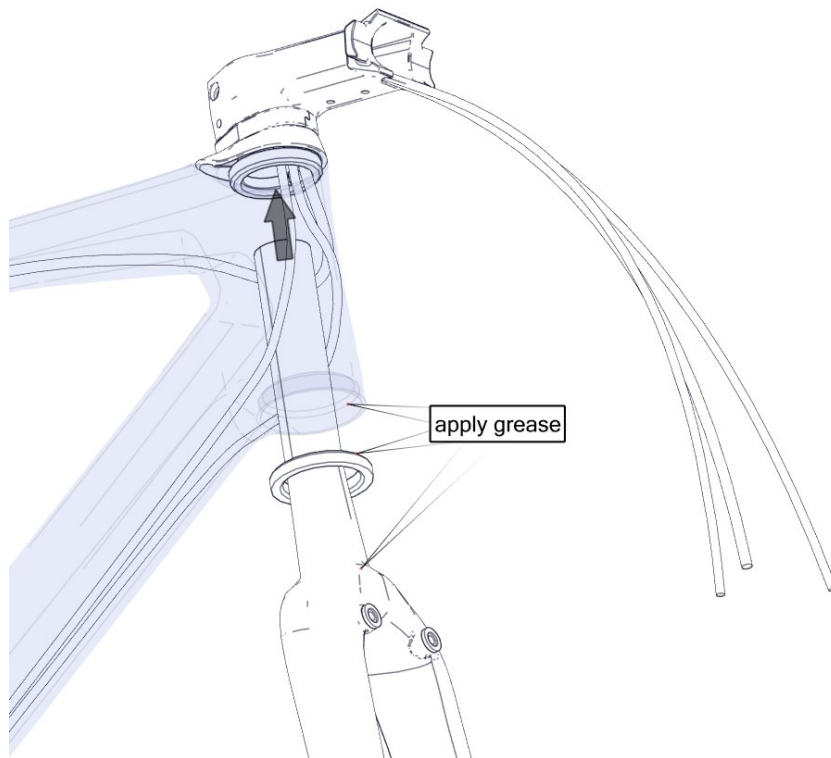

10. Install the top cap and tighten it just enough to eliminate any play, while keeping the bearings running smoothly.
11. Align the stem and tighten the steerer clamp bolts to 5 Nm.
12. Check the steering function. At bigger steering angles, you can feel some resistance caused by the cables, but it should not be excessive. Make sure all cables have enough leeway so you can turn the fork 90 degrees in each direction. At this point, it is still easy to adjust the cable length.
13. Cut the housing to the final length after you installed the components, but double check before that there is enough leeway for turning. If you plan to make changes to your set-up, leave a little bit of extra housing in the form of a bigger curve in front of the stem.

## Handlebar installation

For handlebar compatibility, see chart at the end of this document.

1. Apply friction paste to the contact surfaces of handlebar and stem
2. Slide handlebar clamps over handlebar. This must happen before installing brake levers

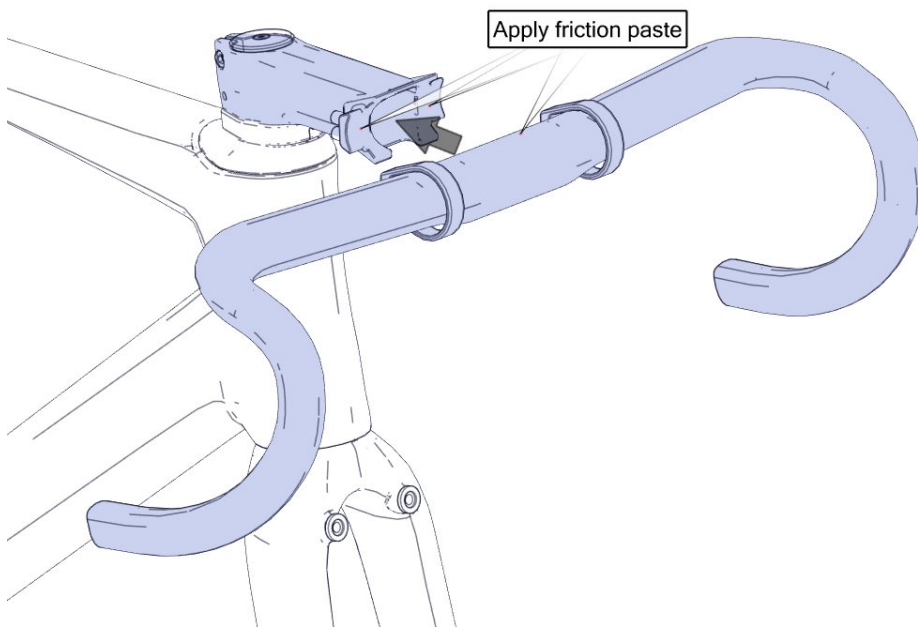

3. Slide handlebar clamps over the protrusions on the side of the stem body. Tighten the four stud screws alternatingly and evenly to 5 Nm. Make sure the gap between the handlebar clamp and the stem body is even. For initial installation, the bolts are coated in thread locker, but if you do adjustments later, use Loctite 243 to secure the bolts. Check the tightness of these bolts before every ride.



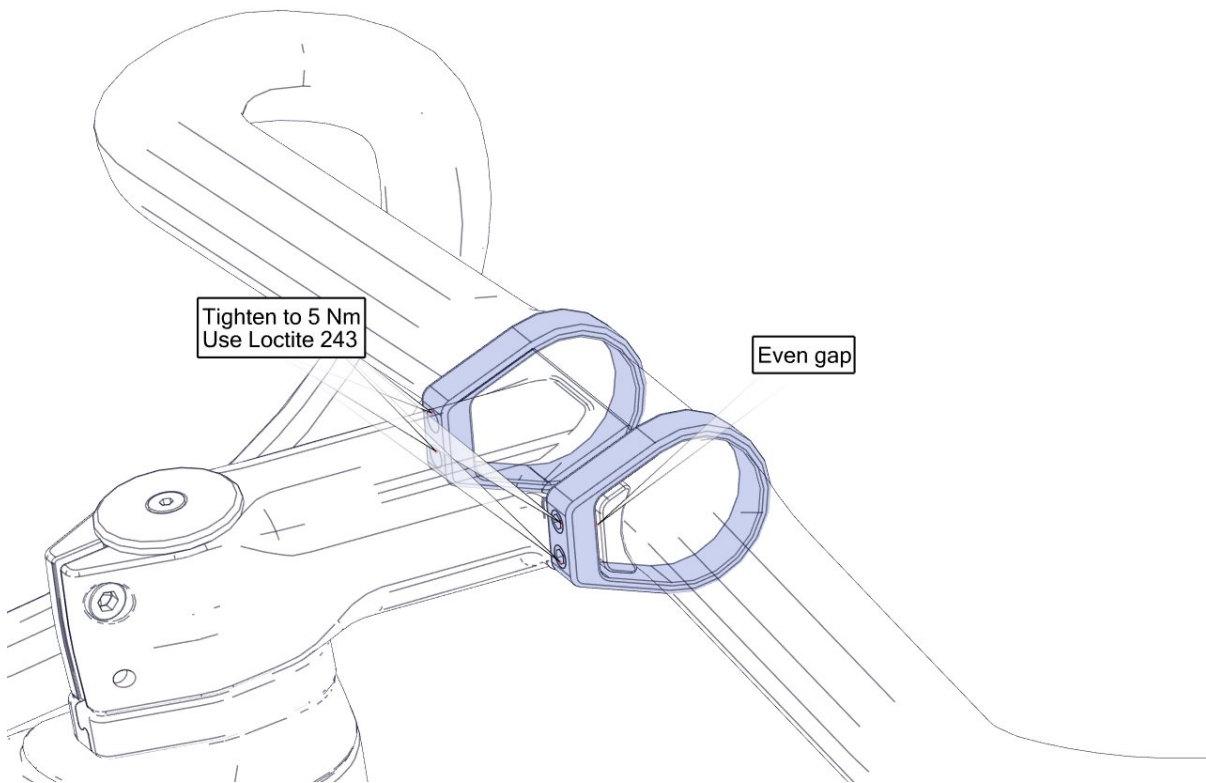

## Saddle installation

1. Loosen the bolts and apply friction paste to the contact surface between the carbon part and the cradle.
2. Insert the saddle into the cradle and tighten the two bolts evenly to 5 Nm.

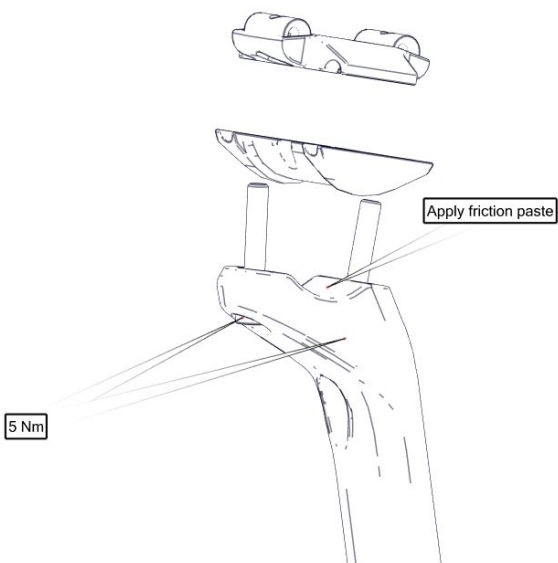

## Schaltauge

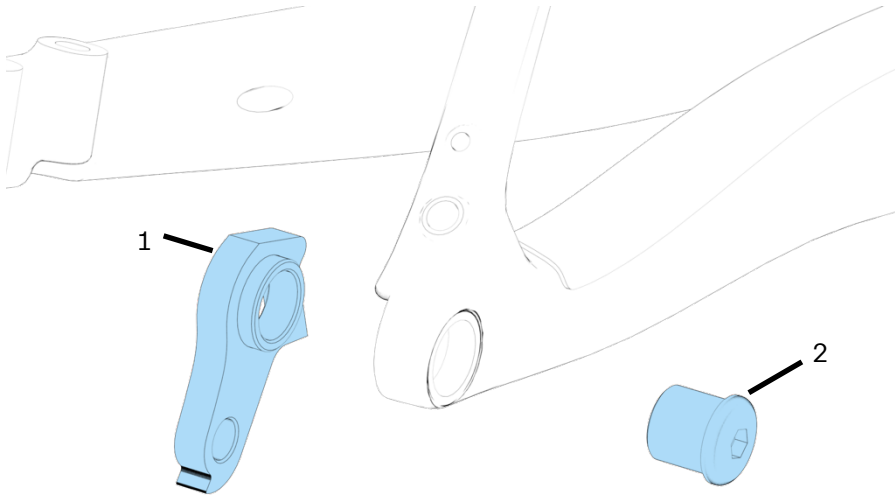

Pos.	Description	Part. No.	Torque
1	RD Hanger		
2	RD Hanger Bolt		10 Nm

Benutze Schraubensicherung (z.B. Loctite 222) auf dem Gewinde vom RD Hanger Bolt (2), bevor du diesen auf 10 Nm anziehst.

## Maintenance

After every ride: check that all bolts are tightened to the specified torque. Clean the bike and inspect for any visible damage. Make sure there is no play in the headset.

Every 1000 km: Remove the fork and inspect for any visible damage on the steerer tube and crown area.

Externally clean and re-grease headset bearings.

## Parts compatibility table

Part	Specification	Comment

# ARC8

Front De-railleur	braze-on	
Shifting Systems	Mechanical, Di2, Etap	Not compatible to Campagnolo EPS
Brakes	direct mount rim brakes/flat mount disc brakes	Disc brakes: 140 mm diameter rotors, or 160 mm with specific brake models or adaptors. 160 mm rotors will fit front and rear. Use bolts for 20 mm disc brake mount height on the rear.
Tires	700C x 28	Because tire width also varies with rim width, make sure the effective tire width is not any bigger than 30 mm.
Seat post	ø27.2	
Headset	ICH	Use the headset delivered with the frameset.
BB	BSA 68	
Chain-rings	53/39-46/30	
Handle-bar	ø31.8 mm, width of clamping area 62 mm minimum	Aero handlebars can have a maximum depth of 37 mm, otherwise clamps cannot be installed.

## Weight limit

This frame is designed and tested for a maximum total weight (rider plus bike plus equipment) of 110 kg.